

Stainless Steel Rotary Vane Pump

L-SSRP



Superior quality Stainless Steel hand operated rotary drum pump, constructed with 304 Stainless Steel body, bung adaptor & suction tube. Stainless Steel rotor with PTFE vanes and seals makes it resistant to corrosion and useful for transferring wide variety of fluids such as water based media, chemicals and all petroleum products.

Self priming rotary operation
Quick and easy delivery of fluid





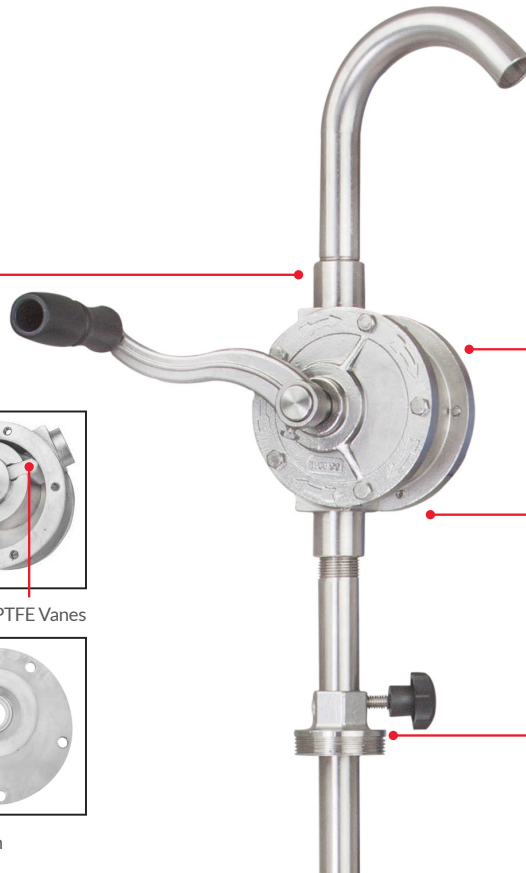
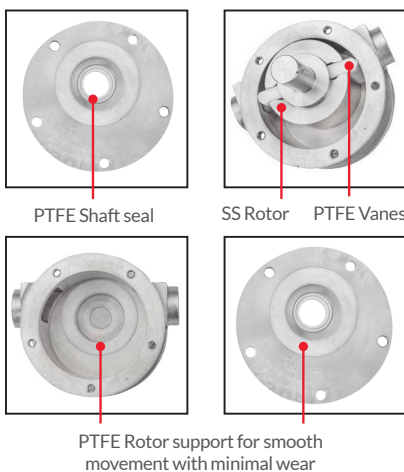

304 Stainless Steel construction
Suitable for most chemicals

Stainless Steel rotor with PTFE vanes and seals
Makes it resistant to corrosion

2" Bung adaptor
Compatible with wide range of 50-205L drums



TECHNICAL SPECIFICATIONS

-  Flow rate: up to 4L /20 turns
-  Container suitability: 50 - 205L drums
-  PTFE vanes
-  Outlet: Spout
-  2" Bung adaptor
-  Stainless Steel 3 piece suction tube
-  Wetted components: Stainless Steel 304, PTFE, Viton®

RECOMMENDED USE WITH

-  Water based media, antifreeze, acids, chemicals, all petroleum based products, lacquer, thinner, urea and DEF

INCLUDED IN THIS PACK

-  Stainless Steel rotary pump body, 2" bung adaptor, handle, discharge spout & 3 piece threaded suction tube