

**Includes models**

OA2005  
OA2008  
OA2551

# RETRACTA®

Auto-Rewind Hose Reels



**macnaught**

## INSTRUCTION MANUAL FOR OXY-ACETYLENE MODEL

### Introduction

Thank you for purchasing a Retracta Auto Rewind Hose Reel.

The Retracta range of hose reels are a breakthrough in industrial quality hose reel design, performance, durability, versatility and cost. The efficiency, safety and convenience benefits of auto rewind hose reels are now available for most situations where a hose is required

### Product Description

Manufactured from the highest quality weather resistant materials, the tough high impact polypropylene is U.V. stabilised, designed for all purpose corrosion free durability. The rewind mechanism is lubricated and sealed for trouble free operation.

This retractable hose reel promotes a neat and tidy good-looking work area, reducing the possibility of accidents, and improves the work environment. Safety is enhanced by low recoil tension even with the hose fully extended.

With your appropriate care, combined with the Macnaught guarantee of dependable after sales service, you will be assured of continuous safe, efficient and reliable product operation.

### Important Information

**PLEASE READ THIS SAFETY INFORMATION CAREFULLY BEFORE USE.**

Read and retain this instruction manual to assist you in the operation and maintenance of this product.

'Cautions' are listed throughout this manual to advise of actions that may cause damage to your equipment.

This hose reel contains a pre-tensioned spring inside the drum assembly. For safety reasons the drum assembly is a non-repairable item.

**DO NOT** under any circumstances try to open the drum assembly. A new drum assembly will be required if the spring is damaged.

**DO NOT** exceed the maximum working pressure stated on the product label.

The maximum installation height is 4.5 meters (15ft) above the ground.



The maximum weight of hose end tools is 2kg (4lb).

This reel contains a positive latching mechanism, which enables the reel to be mounted in any position.

### Product Features

Oxygen and Acetylene Gases are hazardous fluids that can cause serious accidents and injuries if proper precautions and safe practices are not followed.

Operation and maintenance of Oxy-Acetylene Gas equipment should conform to the provisions of the American National Standard Z49-1 "Safety in Welding and Cutting".

Leak test all connections and hose reel swivels prior to initial use (refer "Gas Leak Test Procedure") and repeat at frequent intervals.

It is recommended that leak tests on all equipment be carried out at least once a month, on the replacement of gas cylinders and after any maintenance procedure.

For O-Ring seal lubrication use only 'HYPALUBE A514' or an equivalent inert lubricant when required. **DO NOT** allow oil or grease to come in contact with the swivel or Oxy-Fuel gas equipment.

## Safety Precautions

**ONLY** use this Retracta reel for the Oxy Acetylene gas combination.

**DO NOT** use equipment in poorly ventilated areas.

**RUN** leak tests on your total system including the Hose Reel Swivel frequently. (Refer to the Retracta Operating and Service Instructions).

**EXAMINE** the hose, reel swivel and other equipment for damage (including leaks) should a "Flashback" occur. Replacement of swivel seals is recommended. The use of "Flashback" check valves to reduce the risk of backflow and "Flashback" is also recommended.

**ONLY** use Retracta replacement swivel components and seals as supplied by Macnaught. Obtain replacement parts from your local Authorised Macnaught Service Centre or from Macnaught.

**DO NOT** allow grease and oil to come into contact with any Oxy-Acetylene equipment, components or hose. These materials ignite easily and burn violently in the presence of Oxygen.

**DO NOT** use pipe fitting compounds or thread lubricants in making connections.

**DO NOT** direct the gas flame at the hose or hose reel.

**DO NOT** exceed the recommended maximum Acetylene draw off rate from the cylinder and only operate when the cylinder is upright. Liquid acetone solvent contained in the cylinder can escape and damage the hose, hose reel seals and other equipment.

**DO NOT** work with damaged or faulty equipment or

## Installation Procedure

A) Using 2 x 15mm screws (supplied) attach the carrying handle to the top of the reel.

B) The BU100 mounting bracket (supplied) is suitable for installing the reel up to 1.8mtrs high on a wall or up to 4.5mtrs overhead (see Figures 1 and 2). This bracket allows the reel to swivel in the direction of use. To prevent the reel from swiveling in the overhead position (figure 2) only install the locking bracket RB9 (supplied).

C) Use the optional BB100 bracket to install the reel between 1.8mtrs and 4.5mtrs on a wall or on a bench/floor (see figures 3 and 4).

D) Fix the mounting bracket in the desired location using appropriate fixings (not supplied).

E) BU100 – remove the pin from the bracket, mount the reel onto the bracket and insert the pin to secure the reel.



Fig.1 BU100 - Wall



Fig.2 BU100 - Overhead

F) BB100 – Remove the upper collar by loosening the screw, mount the reel onto the bracket, refit the collar and secure with the screw.



Fig.3 BB100 - Floor/Bench



Fig.4 BB100 - High Wall

G) Use the 8mm screw provided to secure the pin on the BU100 bracket and prevent accidental removal. A padlock (not supplied) can be fitted for additional security on both brackets.

H) The connecting hose should allow the reel to swivel freely on the bracket.

Make all connections dry. **DO NOT** use pipe fitting compounds, thread lubricants, oil or grease. Tighten hose connections with a spanner. Oxygen hoses use only right hand threaded connections. Note Acetylene hoses use only left hand threaded connections.



## CAUTION

**Test the system and all connections for leaks prior to use. Re-test the system frequently (once per month approx) and on each change of gas**

## Latching Operation

Pull out the hose to the required length.

**Note:** A clicking noise can be heard every half revolution of the drum.

**To latch the reel**, allow the reel to slowly retract after hearing the 1st, 2nd or 3rd click.

**To unlatch the reel**, slowly pull out the hose until the clicking noise stops, then let the hose slowly retract until the hose stopper rests against the reel mouth.



## CAUTION

**To prevent injury or damage occurring, do not let go of the hose during rewinding.**

## Maintenance Procedures

This section details the step-by-step procedures that you may require for the general use and maintenance of your reel. Please keep this instruction manual for future reference.

## Gas Leak Test Procedure

Test Oxygen /Acetylene hose lines separately. Ensure that all connections from the cylinder through to the torch are tight.

- 1) Close both torch valves.
- 2) Open the Oxygen cylinder valve and adjust the delivery pressure to 25psi or more.
- 3) Close the Oxygen valve and observe the delivery pressure gauge. If a drop in pressure occurs, re-pressure the hose and test all the connections including the hose, swivel and swivel body by brushing with warm soapy water solution looking for the presence of any bubbles.
- 4) Open the Oxygen valve at the torch and re-close to vent the Oxygen line. Repeat steps 1, 2 and 3 with the Acetylene, with the delivery pressure set at 10 psi. Vent the Acetylene line.
- 5) Replace or repair any faulty items immediately and repeat 'Leak test' procedure.

## Inlet Side Plate Connection

- 1) Pull the hose out until it is fully extended and allow the hose to latch after hearing the 1st, 2nd or 3rd click.
- 2) Place reel on a clean bench with the inlet side plate (3) face up. Remove screw located at the edge of the inlet plate. Rotate plate clockwise.
- 3) Swivel assembly and hose will come away attached to the inlet side plate.
- 4) To replace inlet side plate, suspend reel between your body and edge of bench. Reposition the plate and turn counter- clockwise. Relocate side screw.

## Swivel Seat Replacement



### CAUTION

**Use only genuine Retracta O-Ring replacement kits. The use of any other seals can be dangerous. Ensure that the replacement procedure is carried out in an oil and grease free, clean environment.**

- 1) Pull the hose out until it is fully extended and allow the hose to latch after hearing the 1st, 2nd or 3rd click.

- 2) Place reel on a clean bench with the inlet side plate (3) face up. Remove screw located at the edge of the inlet plate. Rotate plate clockwise.

- 3) Remove the inlet side plate (Refer Inlet Side Plate Connection).

- 4) Remove circlip (5) from end of swivel shaft assembly (1) and slide the inlet shaft from the swivel body (4).

- 5) Carefully remove the existing O-Rings by lifting O-Rings out from grooves using a small screwdriver and cut through the O-Ring onto the screwdriver face. Be careful you do not score o-ring grooves.



### CAUTION

**Do not damage or score inlet shaft surface when removing or cutting o-ring.**

- 6) Before fitting the new o-rings ensure that both the inlet shaft and swivel are thoroughly wiped clean. Apply 'HYPALUBE A514' lubricant (supplied in kit) or equivalent to the o'ring grooves of the inlet shaft.

- 7) Slide the o-ring applicator sleeve (supplied in kit) over the inlet shaft to expose only the furthestmost o-ring groove. Put the first o-ring onto the sleeve and slide up to the exposed groove. Withdraw the sleeve, stopping at each groove, and fit the o'rings one at a time following the same procedure.

- 8) Slide the inlet shaft back into the swivel body and replace the circlip. Note that if the circlip groove is not exposed after fitting, the swivel body is back to front.

- 9) Slide the inlet shaft back into the drum assembly (6), pushing the complete unit home.

- 10) Replace the inlet side plate. (Refer to 'Removal / Replacement of Inlet Connection Side Plate').

## Hose Replacement

- 1) Pull the hose out until it is fully extended and allow the hose to latch after hearing the 1st, 2nd or 3rd click.

- 2) Remove the inlet side plate (3) (Refer "Removal/ Replacement of Inlet Connection Side Plate"). The swivel shaft assembly (1) will come away attached to the inlet side plate.

- 3) Remove hose from swivel body (4). Remove remaining old hose from the mouth of the reel.

- 4) Use only recommended length and type of replacement hose.

## Hose Replacement Continued

5) Feed the new hose through top of reel mouth and into opening on reel drum which gives access to the swivel compartment. Replace and secure the internal hose stopper 5" (13cm) from the end of hose assembly. Reconnect hose.

6) Replace inlet side plate (3) (Refer "Inlet Connection Side Plate").

7) Place the reel in a vertical position and while holding the reel pull the hose out past the last clicking noise and carefully guide the hose onto the drum

8) If the replacement hose is the same length as the old hose no tension adjustment is necessary.

If spring tension adjustment is required refer to the "Spring tensioning and latch plate" procedure.



### **WARNING**

**Test the reel for leaks prior to any further use**

## Spring Tension/Latch Plate

1) Place reel on a clean bench with latching plate (9) face up.

2) Release spring tension by opening tension plate (8) and place handle of a pair of pliers in the exposed slots. Grip the pliers firmly and remove the two screws holding the tension plate (8) and carefully allow the tension plate to slowly unwind counter clockwise.

3) Remove screw holding tension plate and remove tension plate. Remove screw located at the edge of the latching plate. Turn latching plate clockwise and remove, this will expose the latching assembly.

4) To replace latching plate, suspend reel between your body and edge of the bench. Reposition the plate and turn counter clockwise. Relocate side screws, replace tension plate and fixing screw.

5) Reload spring tension by using the same tool (as in step 2) and wind tension plate clockwise until hose stopper is firmly against the reel mouth, some resistance will be felt. Then add approximately six (6) complete 360 deg. tension turns. Hold the tension plate in this position align dimples on tension plate and latching side plate and replace the two screws. Close tension plate and cover.



### **WARNING**

**Test the reel for leaks prior to any further use.**

## Spare Part Diagram & List

Use only genuine Retracta O ring replacement kit & lubricant specified. The use of other materials can be dangerous

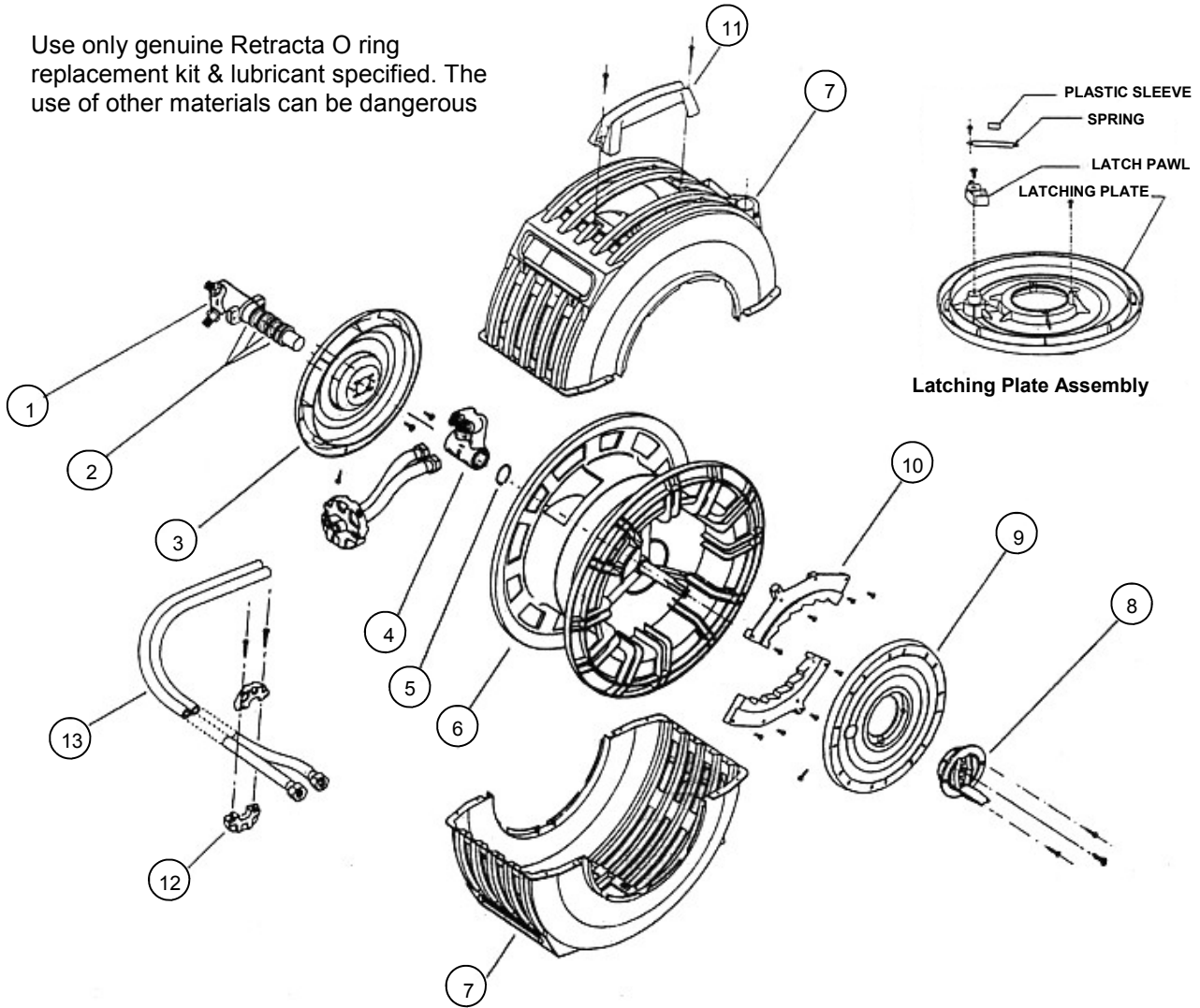

Item	Description	No. off	Spare part
1	Swivel shaft assembly	1	RS79s incl item 2,4,5 (RS53s for USA mod)
2	Swivel seal kit	1	OA-1K
3	Inlet side plate	1	RP34s incl latch side plate assembly
4	Swivel body assembly	1	RS79s incl item 2,4,5 (RS53s for USA mod)
5	Circlip	1	n/a
6	Drum assembly	1	RP35-BLACKS
7	Outer casing set	1	RP36Cs-nominate colour
8	Tension plate assembly	1	RP34s incl latch side plate assembly
9	Latch plate assembly	1	RP114A-Blacks or RP34s for both side plates
10	Ratchet plate	1	RP34s incl latch side plate assembly
11	Carry handle	1	n/a
12	Hose stopper	2	Z22s
13	Hose replacement set	1	RH30s

## Troubleshooting Guide

TROUBLE	CAUSE	REMEDY
Hose will not retract	Hose bunching	Pull hose out and rewind guiding the hose to avoid bunching.
	Spring tension too light	Refer to " Spring tension and latch side plate removal"
	Replacement hose too heavy	Replace hose with recommended hose. Refer to "Hose Replacement"
Reel will not latch	Hose has been pulled past the latching teeth	Allow the reel to slowly retract after hearing the 1st, 2nd or 3rd click
	Broken latching plate or pawl spring	Replace broken components. Refer to "Spring Tension and Latch Sideplate Removal"
Reel leaks	Damaged hose	Replace hose. Refer to "Hose Replacement"
	Loose fittings	Tighten fittings. Refer to "Removal / Replacement of inlet Connection Side Plate"
	Worn swivel seals	Refer to "Swivel Seal Replacement"





Macnaught Pty Limited  
ABN 66 000 075 786

41-49 Henderson Street  
Turlella NSW 2205 Sydney Australia  
Postal Address PO Box 90  
Amcifle NSW 2205 Sydney Australia

T: +61 2 9567 0401  
F: +61 2 9597 7773  
W: [www.macnaught.com.au](http://www.macnaught.com.au)

**Note:**

This product should be disposed of according to all applicable local and national government environment regulations and guidelines.



**For Warranty Terms and Conditions see [macnaught.com.au](http://macnaught.com.au)  
For a list of Australian Service Centres see [macnaught.com.au](http://macnaught.com.au)**