

## DIGITAL OIL METER - 1/2" 725psi

L-DOM35-02



Thank you for purchasing a Lubemate digital oil meter. Your digital oil meter has been designed to reliably dispense engine oil, gear oil, automatic transmission fluid and premix automotive coolants.

This manual assists in operating and maintaining your new digital oil meter. Please take a few minutes to read through this manual before installing and operating your new digital oil meter.



**High accuracy digital oil meter**  
5 digit easy to read, resettable LCD display.

**Variable measurement units**  
can be set to display in litres, gallons, pints & quarts.

**Heavy duty construction**  
makes it suitable to use on a wide range of pumps.

### TECHNICAL SPECIFICATIONS

- Inlet/outlet: 1/2" BSP (F)
- Flow range: 1-35LPM
- Accuracy +/- 0.5%
- Max pressure up to 5,000kPa (725psi)
- Suitable for oils up to SAE 140, engine oils, gear oils, ATF, hydraulic oils and premixed coolants

Mac-rev-1-2018

## GENERAL SAFETY REGULATIONS

1. Keep the work area clean and dry. Damp or wet work areas can result in injury.
2. Keep children away from work area. DO NOT allow children to handle this product.
3. Use the right tool for the job. DO NOT attempt to force small equipment to do the work of larger industrial equipment. There are certain applications for which this equipment was designed. It will do the job better and more safely at the capacity for which it was intended. DO NOT modify this equipment, and do not use this equipment for a purpose for which it was not intended.
4. Check for damaged parts. Before using this product, carefully check that it will operate properly and perform its intended function. Check for damaged parts and any other conditions that may affect the operation of this product. Replace damaged or worn parts immediately.
5. DO NOT overreach. Keep proper footing and balance at all times to prevent tripping, falling, back injury, etc.
6. DO NOT use the equipment when tired or under the influence of drugs, alcohol, or medication. A moment of inattention while operating this equipment may result in serious personal injury.



### WARNING

**WARNING:** This symbol alerts you to the possibility of serious injury or death if you do not follow the instructions.



### CAUTION

**CAUTION:** This symbol alerts you to the possibility of damage to or destruction of equipment if you do not follow the instructions.

### WARNING: Equipment Misuse Hazard

1. Equipment misuse can cause the equipment to rupture or malfunction and result in serious injury.
2. This equipment is for professional use only.
3. Read all instruction manuals, tags, and labels before you operate the equipment.
4. Use the equipment only for its intended purpose.
5. DO NOT alter or modify this equipment.
6. Check equipment daily. Repair or replace worn or damaged parts immediately.
7. DO NOT exceed the maximum working pressure of the lowest-rated system component. Refer to the Technical Data in this manual for the maximum working pressure of this component.
8. Use fluids and solvents that are compatible with the equipment wetted parts. Refer to the Technical Data section of all equipment manuals. Read the fluid and solvent manufacturer's warnings.
9. DO NOT use 1,1,1-trichloroethane, methylene chloride, other halogenated hydrocarbon solvents, or fluids containing such solvents in pressurized aluminum equipment. Such use could result in a chemical reaction, with the possibility of explosion.
10. DO NOT use hoses to pull equipment.
11. Route hoses away from traffic areas, sharp edges, moving parts, and hot surfaces. DO NOT expose the hoses to temperatures above 82°C (180°F) or below - 40°C (- 40°F) .
12. DO NOT lift pressurized equipment.
13. Comply with all applicable local, state, and national fire, electrical, and safety regulations.



### WARNING: Skin Injection Hazard

1. Spray from the dispensing valve, leaks, or ruptured components can inject fluid into your body and cause extremely serious injury, including the need for amputation. Fluid splashed in the eyes or on the skin can also cause serious injury.
2. Fluid injected into the skin may look like just a cut, but it is a serious injury. Get immediately surgical treatment.
3. Do not point the dispensing valve at anyone or at any part of the body.
4. Do not put your hand or fingers over the end of the dispensing valve.
5. Do not stop or deflect leaks with your hand, body, glove, or rag.
6. Use only extensions and no-drip tips that are designed for use with your dispensing valve.
7. Do not use a low-pressure flexible nozzle with this equipment.
8. Follow the pressure relief procedure in this manual before cleaning, checking, or serving the equipment.
9. Check the hoses, tubes, and couplings daily. Replace worn or damaged parts immediately. Do not repair high pressure couplings; you must replace the entire hose.

## GROUNDING



### WARNING:

**Before use the pump, check grounding of the whole system to prevent fire and explosion.**

1. To reduce the risk of static sparking, each device should grounding effectively.
2. Pump: Use a ground wire and clamp as the Fig.2. Get rid of the grounding screw, put the end of the grounding wire into the grounding hole. Lock the bolt to the pump safety.
3. Air and Fluid hoses: Grounding effectively.
4. Air compressor: Follow manufacturer's recommendations.
5. Oil control valve: Connect the pump with proper grounding wire, always hold a metal part of the valve firmly to the side of a grounded metal pail, then trigger the valve.
6. Trolley: Use local applicable trolley. If it is metal trolley, put on the device which is electric, can not put on isolative device surface, such as paper or carton board which without grounding
7. Other parts: Operated with local regulation for grounding.
8. Fluid supply container: Follow the local code. 1. Spray from the dispensing valve, leaks, or ruptured components can inject fluid into your body and cause extremely serious injury, including the need for amputation. Fluid splashed in the eyes or on the skin can also cause serious injury.

## INSTALLATION

These meters must be installed in-line as part of a dispense system as shown in the below figure. However, the typical installation shown is only a guide for selecting and installing an in-line meter. It is not an actual system design.

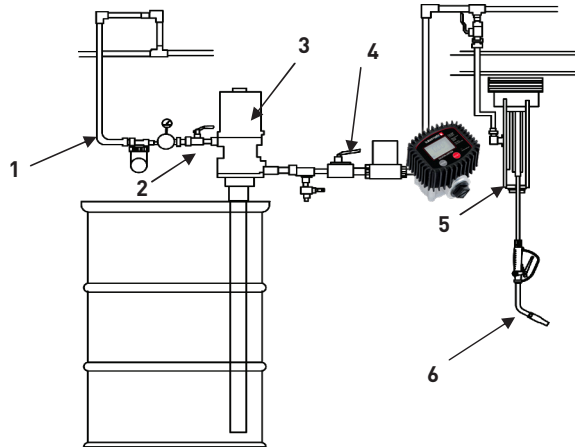

Fig. 2

1. Air supply
2. Shut off air valve
3. Oil Pump
4. Shut off oil valve
5. Hose reel
6. Oil control valve

## OPERATION



### CAUTION

- Never operate the meter with the plastic cover removed. The cover protects the meter from damage due to impact. Meters are factory sealed to keep moisture and dirt out.
- To prevent line contamination, which can cause equipment malfunction or damaged, flush the lines before you install this equipment in the system.

### Display and button usage

AREA 1: FOR LAST DISPENSE CYCLE

AREA 2: FOR MEASUREMENT UNITS

AREA 3:  
FOR ACCUMULATED TOTAL

AREA 4:  
FOR BATTERY CAPACITY

Notes: It will flashing when battery voltage less than 3.3V;

Menu:  
MOVING THE NUMBERS FOR  
ADJUSTING THE CALIBRATION  
AND CHOOSING THE UNITS

Reset:  
CHOOSING THE UNITS AND  
SETTING CORRECTION FACTOR

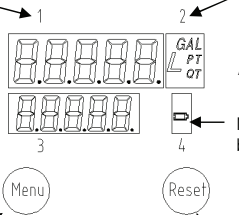

### To activate the digital display

Press the RESET key pad to clear the meter before starting a new dispense cycle. This is the best way to activate the meter, because it also clears the quantity of the last dispense cycle. The digital display can also be activated by pressing the MENU key pad or by running fluid through the meter.

### Calibrating automatically

1. Press Reset key for 1 second and Area 1 shows .000 L.
2. Keep running fluid through the meter until the fluid running out of the certain measuring cylinder. The display will show certain value as \*.\*L, press the Menu key for 3 seconds. The meter will enter instrument calibration mode and Area 1 shows 00\*.\*L.
3. Press Menu key to move the flashing digital, press Reset key to choose number, enter the fluid volume and press Menu key again for 3 seconds, then exit the calibration mode. The calibration settled.

### Show current correction factor

- Press Menu key and Reset key together. The display will show the correction factor, which can be reset.

### Reset the resettlement total

- Press Menu key for 10 seconds, the accumulated total will be reset to be "0".

### To change the measurement units (L / GAL / PT / QT meter only)

1. Move the flashing display to Area 2 by pressing Menu key, then press Menu key to choose measurement unit.
2. Press Menu key over 3 seconds to exit the setting mode.



### CAUTION

1. To be sure the proper amount of fluid is dispensed, always use the same measurement unit for a particular fluid. Units should be changed only by authorized employees.
2. To Verify the Accuracy of an Digital Meter.
3. Use a clean, calibrated container. If using a single container, be sure to clean it after each dispense.
4. Have pump air pressure at the lowest possible setting for dispensing fluid.
5. Put the tip of the nozzle at the bottom of the calibrated container.
6. If the tip of the dispense valve does not reach the bottom of the calibrated container, use a length of plastic tubing over the tip of the nozzle to ensure liquid enters the container from the bottom.
7. Trigger the gun slowly so the fluid immediately covers the tip of the dispense valve.

## TROUBLE SHOOTING GUIDE

Relieve the pressure before you check or repair the dispensing valve. Be sure all other valves and controls and the pump are operating properly.

**!** To reduce the risk of serious injury whenever you are instructed to relieve pressure, always follow the pressure relief procedure.

Problem	Cause	Solution
Leakage	O-ring damaged	<ol style="list-style-type: none"> <li>1. Get the meter off from the dispense system.</li> <li>2. Take off the protector.</li> <li>3. Loosing four the socket head cap screws on the cover of the meter.</li> <li>4. Loosing eight the hex bolts on the bottom of the meter.</li> <li>5. Take off the seat.</li> <li>6. Check the o-ring, replacing the o-ring if it is damaged.</li> <li>7. After replacing the o-ring, assemble the meter and fix it back to the dispense system.</li> </ol>
No display	Loosing battery	<ol style="list-style-type: none"> <li>1. Get the meter off from the dispense system.</li> <li>2. Take off the protector.</li> <li>3. Take off the labels sticks on the bottom of the meter.</li> <li>4. Loosing the five socket head cap screws on the bottom of the meter.</li> <li>5. Take off the seat.</li> </ol>
	Battery out of power	<ol style="list-style-type: none"> <li>6. Check the battery, replacing the battery if it is out of power.</li> <li>7. After replacing the battery, assemble the meter and fix it back to the dispense system.</li> </ol>
Wrong reading	Correction coefficient error	Reset the correction factor (follow the instructions on Page 4).

## LIMITED WARRANTY

1. The manufacturer warrants this product against defects in material and craftsmanship, for a period of two years from date of purchase, but not including wearing parts.
2. Manufacturer's liability is limited to replacement or repair of defective material within the warranty period, when returned freight prepaid to the distributor or their designated service depot.
3. The warranty does not cover damage caused by accident, misuse or faulty installation.
4. The product must be installed and maintained in compliance with the instructions.

## EXPLODED AND PARTS LIST

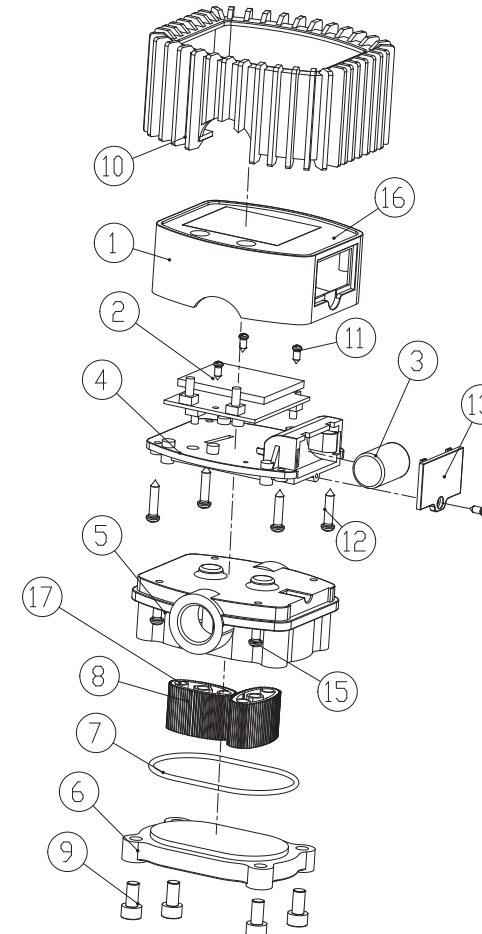

Part No.	Description	Q'ty
1	Meter Cover	1
2	Main Circuit Board	1
3	Battery	1
4	Join Board	1
5	Meter Holder	1
6	Seat	1
7	O-ring	1
8	Oval Gear	2
9	Bolt	4
10	Rubber Protector	1
11	Screw	4
12	Screw	4
13	Battery Cover	1
15	Shaft	2
16	Front Label	1
17	Magnetic Rod	4

No spare parts available.

**NOTE:** This product should be disposed of according to all applicable local and national government environment regulations and guidelines!





Lubemate® is a practical, cost-effective range of equipment brought to you by the trusted team at Macnaught.

All Lubemate products are specially selected by our experienced technical team at Macnaught®, ensuring they meet our strict quality standards.



**Macnaught Pty Ltd**

41-49 Henderson St, Turrella NSW 2205. Australia

**Ph:** 1800 185 102 **Fax:** +61 2 9597 7773

**Email:** [info@macnaught.com](mailto:info@macnaught.com) **Website:** [macnaught.com](http://macnaught.com)